



Advanced Wheelend Technologies

Service bulletin

Heavy-Duty installation for BBOC-152500 bushing

Regular "OPTIMUM-CONTACT" installation is very efficient for street use, highway use and all paved road applications. However, experience has shown us that off-road applications like excavation, forestry and mining equipments require special attention.

This service bulletin explains the improvements we have made to satisfy the special needs of these applications.



The main difference between the conventional system and the "heavy-duty" system is that the conventional systems uses regular grease seals, while the "heavy-duty" system uses double lipped oil seals featuring a spring-loaded oil lip and a dust lip to prevent contamination. These seals are also made of a special elastomere, highly resistant to heat, solvents, acids, and numerous chemicals.

The bushings are installed in the same way as usual, only that they are drilled after installation to make a vent to purge the grease during the lubrication.

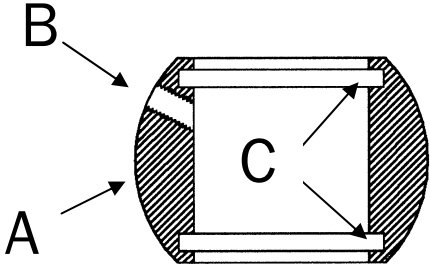
Bushing identification

		A - Bushing
		B - Grease fitting hole
		C - Seal grooves

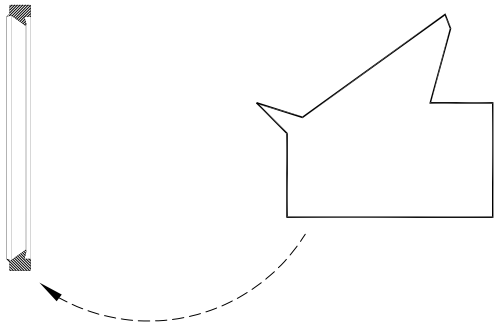
Special seal identification (cross sectional view)

	
Part # SL-WV-130 Seal	Part # SL-2500-HD-SWC Seal

Installation procedure

	<p>Step 1; Install bushing as shown in trailer axle procedure manual steps 2 through 6. Install the dust seals as shown in step 8 of same manual or service bulletin SBOC-111.1</p>
	<p>Step 2; Insert camshaft through spider bushing and slide all necessary shims and snap ring + an extra shim after the snap ring, then slide on a SL-2500-HD-SWC seal onto the cam making sure the contact lip is facing the bushing's holding plate. Move all this hardware a few inches down the shaft.</p>
	<p>Step 3; Slide the cam into the hanger bracket bushing and keep going all the way through. Shim the cam for proper end play and secure it in place by installing the snap ring in its groove.</p>
	<p>Step 4; Slide a SL-2500-HD-SWC seal onto the cam making sure the contact lip is facing the bushing's holding plate and shim the brake adjuster in order to keep the seal in full contact with the side of the bushing.</p>
	<p>Step 5; On the other side of the hangar bracket, slide the SL-2500-HD-SWC seal onto the cam making sure the contact lip is in full contact with the bushing and back it up with extra shim and a solid "tie rap" secured onto the camshaft to hold it there.</p>
	<p>Step 6; Lubricate bushings thoroughly and generously until you can see it coming out behind the Heavy-Duty seals.</p>

Lubricate bushings and check the breather operation to make sure that grease is purged through.

Two SL-2500-HD-SWC seals + a shim washer are needed for each camshaft.

For any questions regarding this service bulletin please call our toll free tech support hot line at:

1-877-765-9629